

ISOMETER® IRDH275-4xx

PV insulation monitoring device for unearthed power supplies (IT systems) in photovoltaic power systems up to AC 1150 V/DC 1760 V



ISOMETER® IRDH275-4xx

PV-Insulation monitoring device for unearthed power supplies (IT systems) in photovoltaic power systems up to AC 1150 V/DC 1760 V



ISOMETER® IRDH275

Device features

- Insulation monitoring for unearthed systems AC 0...1150 V/DC 0...1760 V
- Two separately adjustable response values 1 kΩ...10 MΩ
- **AMP^{Plus}** measuring principle (European Patent: EP 0 654 673 B1)
- Automatic adaptation to the system leakage capacitance
- INFO button to display device settings and the system leakage capacitance
- Self monitoring with automatic alarm
- Automatic self test, selectable
- Connection for external kΩ indication
- TEST and RESET button
- External TEST/RESET button can be connected
- Two separate alarm relays with two potential-free changeover contacts
- N/O or N/C operation, selectable
- Backlit LC display
- RS-485 interface

Certifications



Product description

The ISOMETER®s of the IRDH275 series are used in combination with the AGH150W-4 coupling device to monitor the insulation resistance of unearthed main circuits (IT systems) AC 1150 V/DC 1760 V. Solar systems containing inverters and isolating transformers are often designed as IT systems. IRDH275 variants using the **AMP^{Plus}** measurement method capable of adapting to slow voltage fluctuations meet the particular requirements of modern solar systems. Due to wide spatial distribution and EMC interference suppression methods often high leakage capacitances against earth occur in these systems. Considering this, the IRDH275 automatically adapts to the system conditions in order to optimise the measuring time.

An external supply voltage allows deenergised systems to be monitored too.

Application

- Solar systems with directly connected inverters
- Solar systems with high system capacitances of up to 3000 μF
- Solar systems with high but slow voltage fluctuations

Function

When the insulation resistance between the system conductors and earth falls below the set response value, the alarm relays switch and the alarm LEDs light up. Two separately adjustable alarm relays allow to distinguish between “prewarning” and “alarm”. The measured value is indicated on the LC display or an externally connectable measuring instrument. In this way any changes, for example when outgoing circuits are connected to the system, can be recognised easily. The fault message can be stored. The fault memory can be reset by pressing the RESET button. By pressing the TEST button, the function of the device as well as the connections to earth can be tested. Pressing the INFO button provides important information, such as the existing system leakage capacitance or device settings.

The function of the device and the earth connections are continuously monitored. When a fault occurs, the system fault relay switches and the alarm LED “system fault” lights up. The parameterisation of the device can be carried out via the LC display or the function buttons integrated in the front plate.

Measurement method

AMP^{Plus} The IRDH275 series uses the patented **AMP^{Plus}** measurement method. This measurement method allows concise monitoring of modern power supply systems, also in case of extensive, directly connected DC components and high system leakage capacitances. By using this method the requirements of the product standard DIN EN 61557-8 (VDE 0413-8):2015-12 annex C are met.

Standards

The ISOMETER® has been developed in compliance with the following standards:

- DIN EN 61557-8 (VDE 0413-8):2015-12
- IEC 61557-8:2014-12
- IEC 61557-8:2014/COR1:2016
- DIN EN 61557-8 Ber 1 (VDE 0413-8 Ber 1):2016-12

Control elements IRDH275

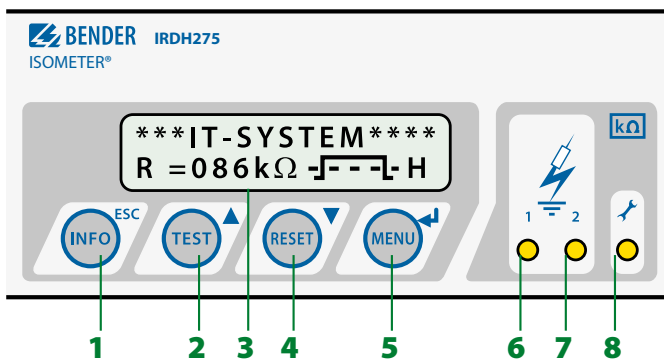

- 1 - INFO button: to query standard information
ESC button: back menu function
- 2 - TEST button: to call up the self test
Arrow-up button: parameter change, scroll
- 3 - LC display
- 4 - RESET button: to delete installation and fault messages
Arrow-down button: parameter change, scroll
- 5 - MENU button: to call up the menu system
Enter button: to confirm parameter changes
- 6 - Alarm LED 1 lights: insulation fault, first warning level reached
- 7 - Alarm LED 2 lights: insulation fault, second warning level reached
- 8 - LED lights: system error detected

Wiring diagram

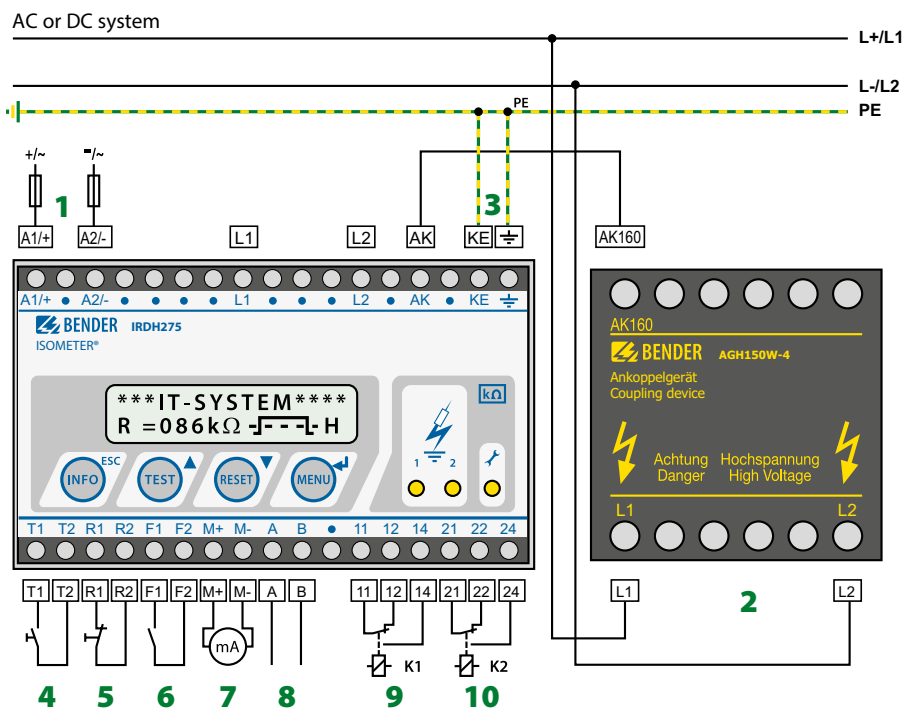

- 1 - Supply voltage U_s (see ordering information) via 6 A fuse; for UL and CSA applications, it is mandatory to use 5 A fuses.
- 2 - Connection to the system to be monitored:
Connect terminal L1 to conductor L+, terminal L2 to conductor L-
- 3 - Separate connection of equipotential bonding to PE and KE
- 4 - External TEST button (N/O contact)
- 5 - External RESET button (N/C contact or wire jumper), when the terminals are open, the fault message will not be stored.
- 6 - STANDBY by means of the function input F1, F2: when the contact is closed, the insulation resistance is not measured.
- 7 - Current output, galvanically isolated: 0...400 μ A
- 8 - RS-485 interface
- 9 - Alarm relay: alarm 1
- 10 - Alarm relay: alarm 2/system

* 7- and 8-: When galvanic isolation is required, only either the current output or the RS-485 interface can be used since they are not galvanically isolated from each other.

Wiring diagram

PV generator unearthed (IT system) with nominal voltage \leq AC 1150 V/DC 1760 V and ISOMETER® IRDH275 with coupling device AGH150W-4

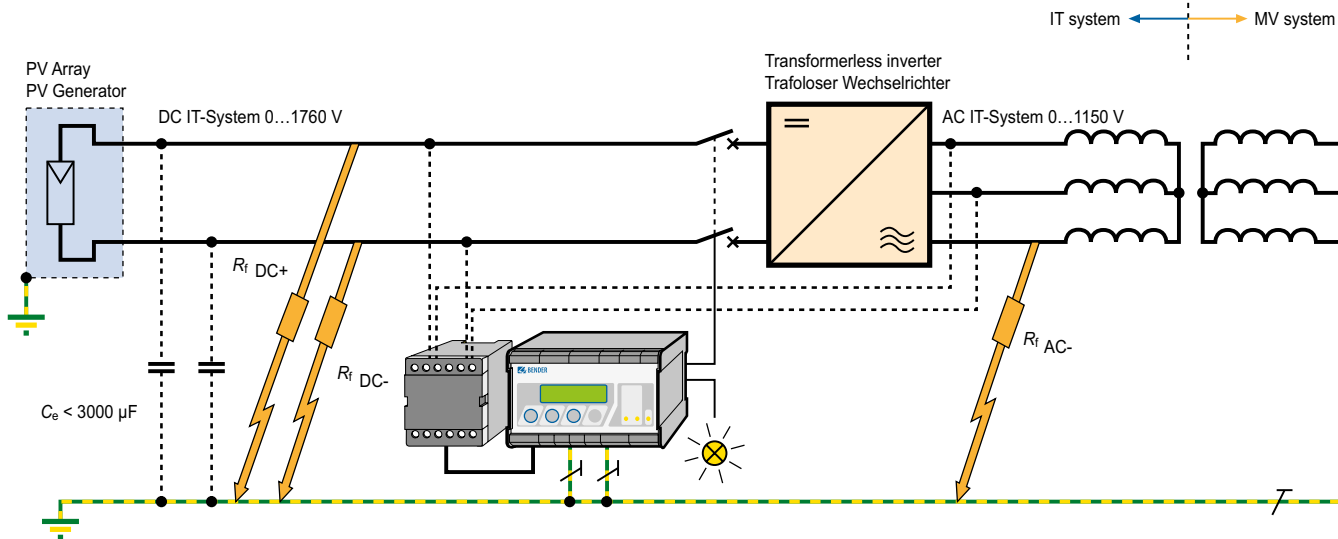

Ordering details

Nominal system voltage U_n		Supply voltage U_s		Type	Art. No.
AC	DC	AC	DC		
0...1150 V*	0...1750 V*	88...264 V	77...286 V*	IRDH275-435+AGH150W-4	B91065142
		19.2...55 V	19.2...72 V	IRDH275-427+AGH150W-4	B91065143

* Absolut values

Suitable system components

Description	Type	Art. No.
External k Ω measuring instruments	7204-1421	B986763
	9604-1421	B986764

Dimension diagram XM112

Dimensions in mm

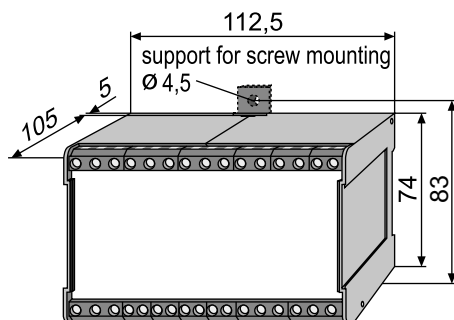

Dimension diagram X150

Dimensions in mm

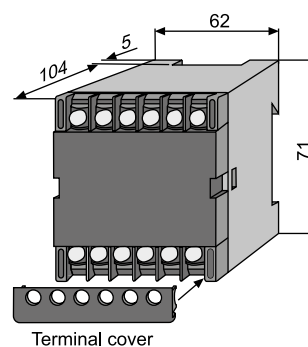

Technical data
Insulation coordination in acc. with IEC 60664-1

Rated insulation voltage	DC 1500 V
Rated impulse voltage/pollution degree	10 kV/3

Voltage ranges
IRDH275-4... with AGH150W-4:

Nominal voltage range U_n	AC 0...1150 V*
Nominal voltage range U_n	DC 0...1760 V*
Nominal voltage range U_n (AGH150W-4)	DC 0...1600 V (for UL applications)

IRDH275-435:

Supply voltage U_s (see nameplate)	AC 88...264 V*
Frequency range U_s	42...460 Hz
Supply voltage U_s (see nameplate)	DC 77...286 V*

IRDH275-427:

Supply voltage U_s (also see nameplate)	AC 19.2...55 V*
Frequency range U_s	42...460 Hz
Supply voltage U_s (also see nameplate)	DC 19.2...72 V*

IRDH275...:

Power consumption	≤ 14 VA
-------------------	---------

Response values

Response value R_{an1} (Alarm 1)	1 kΩ...10 MΩ
Response value R_{an2} (Alarm 2)	1 kΩ...10 MΩ
Relative uncertainty (20 kΩ...1 MΩ) (acc. to IEC 61557-8:2007-01)	±15 %
Relative uncertainty (1 kΩ...20 kΩ)	-2...+4 kΩ/+20 %
Relative uncertainty (1 MΩ...10 MΩ)	0.2 MΩ/+20 %
Response time t_{an} at $R_f = 0.5 \times R_{an}$ and $C_e = 1 \mu\text{F}$	≤ 150 s
Hysteresis (1 kΩ...10 kΩ)	+2 kΩ
Hysteresis (10 kΩ...10 MΩ)	25 %

Measuring circuit

Measuring voltage U_m	≤ 50 V
Measuring current I_m (at $R_f = 0 \Omega$)	≤ 193 μA
Internal DC resistance R_i	≥ 2,4 kΩ
Impedance Z_i at 50 Hz	≥ 2,4 kΩ
Permissible extraneous DC voltage U_{fg}	≤ DC 1500 V
Permissible system leakage capacitance C_e	999 μF
Permissible system leakage capacitance at insulation value ≤ 10 kΩ C_e	2 μF

Displays

Display (backlit)	two-line display
Characters (number)	2 x 16
Display range measured value	1 kΩ...10 MΩ
Operating uncertainty (20 kΩ...1 MΩ) (acc. to IEC 61557-8:2007-01)	±15 % **
Operating uncertainty (1 kΩ...20 kΩ)	±1 kΩ / ±15 % **
Operating uncertainty (1 MΩ...10 MΩ)	±0.1 MΩ / ±15 % **

Outputs

TEST/ RESET button	internal/external
Cable length TEST/RESET button external	≤ 10 m
Current output for measuring instrument SKMP (scale centre point = 120 kΩ):	
Current output IRDH275 (load)	400 μA (≤ 12.5 kΩ)
Accuracy current output (1 kΩ...1 MΩ) in relation to the displayed measured value	±10 %, ±1 kΩ

Serial interfaces

Interface/Protocol IRDH275	RS-485/ASCII-isoData
Connection	terminals A/B
Cable length	≤ 1200 m
Shielded cable (shield on one side to PE)	two-core, ≥ 0.6 mm ² , e.g. J-Y(St)Y 2 x 0.6
Terminating resistor	120 Ω (0.5 W)

Switching elements

Switching elements	2 changeover contacts: K1 (Alarm 1), K2 (Alarm 2, device fault)
Operating principle	N/O or N/C operation
Factory setting	N/O operation
Electrical endurance, number of cycles	12000
Contact class	IIB (DIN IEC 60255-0-20)
Rated contact voltage	AC 250 V/DC 300 V
Making capacity	AC/DC 5 A
Breaking capacity	2 A, AC 230 V, cos phi = 0,4 0,2 A, DC 220 V, L/R = 0,04 s
Contact rating at DC 24 V	≥ 2 mA (50 mW)

Environment/EMC

EMC	acc. to IEC 61326-2-4:2006-06 Ed. 1.0
Shock resistance IEC 60068-2-27 (device in operation)	15 g/11 ms
Bumping IEC 60068-2-29 (during transport)	40 g/6 ms
Vibration resistance IEC 60068-2-6 (device in operation)	1 g/10...150 Hz
Vibration resistance IEC 60068-2-6 (during transport)	2 g/10...150 Hz
Ambient temperature (during operation)	-10...+55 °C
Storage temperature range	-40...+70 °C
Climatic class acc. to IEC 60721-3-3	3K23

Connection

Connection	screw-type terminals
Connection properties	
rigid/flexible	0.2...4 mm ² /0.2...2.5 mm ²
flexible with ferrules, without/with plastic sleeve	0.25...2.5 mm ²
Tightening torque	0.5 Nm
Conductor sizes	AWG 24...12

Other

Operating mode	continuous operation
Mounting	display-oriented
Distance to adjacent devices	≥ 30 mm
Protection class, internal components (DIN EN 60529)	IP30
Protection class, terminals (DIN EN 60529)	IP20
Type of enclosure	X112, free from halogen
DIN rail mounting	DIN EN 60715/IEC 60715
Flammability class	UL94V-0
Documentation number	D00331
Weight	≤ 510 g

* Absolute values

** = under test conditions according to IEC 61326-2-4, the tolerances may double



Bender GmbH & Co. KG

P.O. Box 1161 • 35301 Grünberg • Germany

Londorfer Straße 65 • 35305 Grünberg • Germany

Tel.: +49 6401 807-0 • Fax: +49 6401 807-259

E-mail: info@bender.de • www.bender.de



BENDER Group